

BONENG

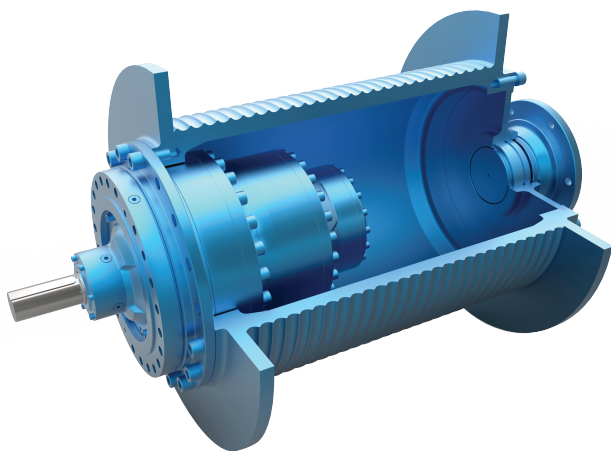

**PW行星内
藏式卷扬齿
轮箱使用手
册**

**PW Winch
Gear Units
Use Manual**

07/2023

注意事项！必须严格遵守以下各项！

本说明书中所注明数据仅用于产品使用说明、应用示例和建议。如果在使用过程中要参考注明数据，需进行技术论证。

我们的产品会随着使用时间的积累而不断更新与改进，说明书中若存在未能及时更新的信息，请给予理解。

本说明书中的附图仅用于产品操作说明，所供货的产品可能与图示有所差别。

本说明书的所有权利归 BONENG 公司所有，包括复制和转发权等。

目录

重要提示	01
1.关于本产品	02
1.1 铭牌说明	02
1.2 型号说明	02
1.3 性能说明	02
1.4 产品说明	02
1.5 注意事项	04
2.安全注意事项	04
2.1 正确使用	05
2.2 不正确使用	05
2.3 人员资质	05
2.4 一般安全注意事项	05
3.运输和存放	05
3.1 运输	06
3.2 存放	06
4.安装	06
4.1 拆除包装	06
4.2 安装条件	07
4.3 安装方位	07
4.4 安装说明	07
5.调试	12
5.1 减速机加注润滑油	12
5.2 液压马达驱动卷扬机调试	13
5.3 电机驱动卷扬机调试	15
6.维护与维修	15
6.1 清洁与护理	15
6.2 检查	16
6.3 维护计划	16
6.4 维护说明	17
6.5 维修	18
7.拆卸与拆换	18
8.故障查询与故障排除	18
9.售后服务	41

Note: You must conform to the following instructions

All the data in this instruction is only for the use manual, application example and suggestion. If need refer to the data when operating, it needs technical test.

Our products will be updated when time goes by, if there is no prompt updated information, please give us support.

The drawing in the instruction is only for the use manual, the exact products may be a little different.

All rights are reserved by BONENG, including copy rights and transfer rights.

Contents

Important notes	21
1.About products	22
1.1 The name plate	22
1.2 Gear unit type description	22
1.3 Feature description	22
1.4 Products description	22
1.5 Notes	24
2.Safety notes	24
2.1 Proper use	25
2.2 Improper use	25
2.3 Qualified staff	25
2.4 Safety notes	25
3.Transportation and storage	25
3.1 Transportation	26
3.2 Storage	26
4.Assembly	26
4.1 Remove the packaging	26
4.2 Assembly condition	27
4.3 Mounting position	27
4.4 Assembly description	27
5.Debugging	32
5.1 Oil lubrication add	32
5.2 Hydraulic motor drive debugging	33
5.3 Motor drive debugging	35
6.Maintenance and repair	35
6.1 Clean and check	35
6.2 Examine	36
6.3 Maintenance plan	36
6.4 Maintenance notes	37
6.5 Repair	38
7.Dismantling and replace	38
8.Faults checking and resolve	38
9.After sales service	43

重要提示

在安装操作过程中，
请注意本说明书中的安全提示和警告提示！



有电危险
可能产生的后果：死亡或者严重伤害



危险情况
可能产生的后果：轻微伤害



有害情况：
可能产生的后果：损坏传动装置和环境



使用建议和有用的信息



◆遵守本手册的规定可以让装置无故障运行，同时也满足质量缺陷索赔的要求，因此在使用传动装置进行工作之前，请您先阅读本说明书；

◆本说明书包含重要的安装维护提示，请将说明书保管在靠近设备的位置，以便安装维护参阅；

1 关于本产品

本产品为PW行星齿轮箱内藏驱动卷扬机，在以下章节中简称为卷扬机。

1.1 铭牌说明

⊕ BONENG ⊕		CE ⊕
Type		
n ₂		RPM
P ₁	kW	T ₂ N·m
n ₁	RPM	i
Oil	L	kg
NO.	Date	
⊕		⊕



铭牌上的数据十分重要，请仔细阅读，并保持其整洁，当需要服务时，请提供铭牌上的产品编号、使用时间及故障类型。

1.2 型号表示

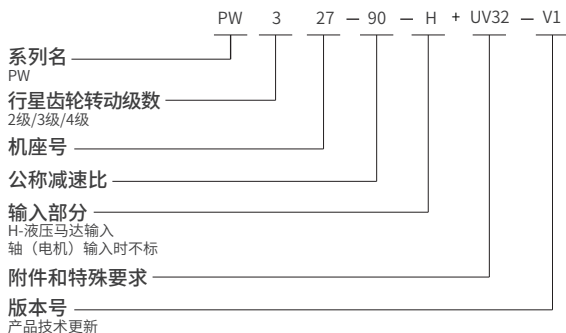

1.3 性能说明

PW行星齿轮箱额定动态输出扭矩范围11.2kN·m-1500kN·m钢丝绳额定单绳拉力范围67kN-1950kN。具体产品的性能参数请查阅样本或 BONENG 公司相关技术资料

1.4 产品说明

PW行星齿轮箱内藏驱动卷扬机由PW行星齿轮箱、驱动单元、滚筒、末端支撑和相关附件组成。适用于起重机、桩工机械、船舶等设备，因其齿轮箱安装于滚筒内部，结构紧凑，有效节省了安装空间。

1.4.1 齿轮箱

PW行星齿轮箱输出扭矩大、速比范围广、性能可靠。

该行星齿轮箱太阳轮、行星轮均采用优质合金钢渗碳淬火处理，内齿圈采用优质合金钢表面硬化处理，齿轮均磨齿加工。

行星架和中间连接法兰采用球墨铸铁材料，承载能力高。

1.4.2 驱动单元

卷扬机的驱动单元既可以是液压马达也可以是电机见图1、图2。

 液压马达驱动系统为开式系统时，通常配备相应的集成阀块（具有压力缓冲、负载平衡、制动器开启等功能）以确保卷扬机的正常工作。



图1



图2

1.4.3 制动器

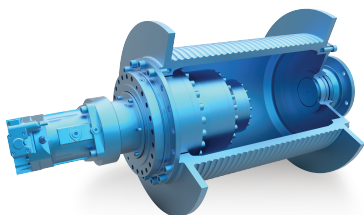
卷扬机配装有制动器，确保卷扬机在停机状态下能够可靠锁止，保证使用安全：

驱动单元为液压马达时，所配制动器为液压松脱-弹簧制动多片式制动器。多片式制动器为弹簧加载、液压释放，只能作为停车制动器使用。
驱动单元为电机时，通常配有电磁块式制动器，块式制动器为电磁开启常闭制动器。

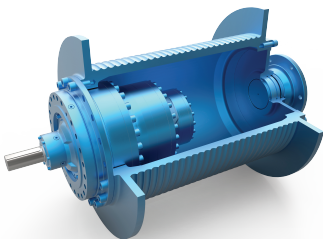
1.4.4 滚筒

滚筒为铸造式整体结构，滚筒表面分为光面、普通绳槽、特殊绳槽三种：

光面滚筒适用于单层绕绳且使用频率不高的辅助场合。

普通绳槽滚筒适用于三层以下绕绳场合。

特殊绳槽滚筒用于三层以上绕绳场合。可有效地避免乱绳现象，延长钢丝绳寿命。

1.4.5 附件

根据客户实际需求，卷扬机附件包括滚筒、滚筒支架、末端支撑、底座等，具体按客户要求。

1.5 注意事项



用户方面对卷扬机进行的任何有可能影响其安全性和可靠性的改造、变更都是不允许的。

在卷扬机上不得进行焊接作业。不得将卷扬机作为焊接作业的接地点，这样会引起精密的轮齿和轴承零部件无可挽回的损坏。

一旦在运行过程中发现异常现象（如温度过高或出现异常声响），应立即停止设备并进行故障检查和排除。

务必使用BONENG的原装附件和备件，以排除因使用不合适备件造成的事故。



取油样和排放润滑油时请小心打开取油样口和排油口，防止油液飞溅、溢出。



卷扬机处于运行状态时，不可靠近。

只有在卷扬机处于静止并且卸载的条件下，方可进行拆卸。

2 安全注意事项

卷扬机根据普遍公认的技术规程生产制造而成。尽管如此，如违反本说明书中的以下安全事项或者进行违规操作与使用，仍有可能造成人员和财物损伤的危险。

2.1 正确使用

卷扬机是一个成套设备，由多部分组成，用户不得私自进行拆卸或改装。

卷扬机可用于起升、变幅、牵引等工况。

严格遵守产品样本或者相关技术文件中所述的运行条件、运行参数和功率极限规定。

严格按照产品样本或者相关技术文件中所述规定进行使用和操作。

只能在设备无故障且各性能参数可满足的情况下使用。

2.2 不正确使用

以下所述使用方式均视为不正确并且不允许的。对于不正确使用产生的后果，BONENG 公司概不负责。不正确使用带来的风险由用户自行承担：



违反章节 2.1 “正确使用”所述事项进行使用。



将卷扬机拆卸并将其附件用于其它用途。

将卷扬机置于有侵蚀性物质和气体的环境中使用。



将卷扬机及其附件用于具有爆炸危险的环境。

将卷扬机用于载人等工况。

2.3 人员资质

本文档中所述的内容需要机械、电气、液压方面的相关专业知识和指导。

卷扬机的使用还需要相关的吊装技术方面的知识。

为了确保产品安全的使用，所有作业只能由具有相关资质、经过相关作业培训的专业人员完成，或在一名专业人员的指导下由具有资质的被指定人员完成。

2.4 一般安全注意事项



请遵守有效的事故防范和环保规范。

请遵守使用设备所在地国家的安全规范和法规。



设备在运行期间其局部温度（齿轮箱表面、液压马达壳体、电机壳体等）最高可能达到90°C，请勿触摸设备表面。



易燃物品可能造成事故或财物损失，例如：润滑油、液压油。请在处理易燃物品时遵守相关生产商的产品数据清单和安全数据清单中的规定。

接触有损健康的物品可能存在中毒或受伤危险，例如：润滑油、液压油。请在处理有损健康的物品时遵守相关生产商的产品数据清单和安全数据清单中的规定。

3 运输和存放

请在运输前仔细阅读本章节说明，并严格按照相关规定存放设备。

3.1 运输



请遵守有关运输的国家法律和规范。

请确保产品在用吊车或者叉车吊装时务必由具有资质证明的人员进行操作。

请根据产品的重量和尺寸选择举升工具（吊车或叉车）和吊装工具（链条和吊钩或皮带和绳索）。

请确保产品在运输过程中可靠固定。

产品在运输过程中做到轻取轻放，以免损坏。

3.2 存放



产品需要在防腐条件下进行保藏。

产品在通风的房间内存放其防锈蚀性能最长可保持供货后的12个月。

产品在空调房间内存放其防锈蚀性能最长可保持供货后的18个月。务必排除高湿度空气状态。

4 安装

在安装之前必须备好以下文档：

产品的尺寸外形图。

产品的相关技术数据。

产品的使用说明书。

4.1 拆除包装

产品标准采用木质运输箱包装后供货。为了防止潮湿，供货采用防锈蚀膜包装并配有干燥袋。拆卸产品包装时按以下步骤操作：

- 1、请将包装置于一个平展、有足够承载力的地板上。
- 2、务必从上面打开包装。
- 3、检查供货是否有运输损坏以及是否完整。
- 4、检查产品型号是否正确。
- 5、用合适的举升工具和吊装工具将产品从包装中取出。
- 6、将产品放置于合适的地方，防止倾倒。



请根据您所在国家的相关规定对包装废品进行废处理。

4.2 安装条件

确认产品完好无损（在运输或储存过程中未损坏）。

确认现场环境条件与铭牌内容相符。

确保卷扬机所固定在的机架或平台架有一定的耐扭曲强度。机架必须能承受设备重量和设计扭矩的负荷。

确保卷扬机所有液压油口和润滑油口均进行密封保护处理，以防止油口污染。

在户外安装时应该避免阳光的直射，一定要避免热力集中影响齿轮箱和驱动单元的正常性能。

确保给卷扬机留出足够的活动空间以备以后进行维护保养和维修。

制造厂家对于不正确的组装和安装所造成的任何损伤概不负责。



标准产品：环境温度： $0^{\circ}\text{C}\sim+40^{\circ}\text{C}$ ；无油、酸、有害气体、蒸汽、放射性物质等。

4.3 安装方位

卷扬机的推荐安装方位为水平安装。

卷扬机的安装面可以允许有一定角度的倾斜，但必须保证安装面与卷扬机回转中心平行，以防止乱绳。

卷扬机的安装方位影响其出绳方向，请务必合理安装。

4.4 安装说明

以下安装说明涵盖液压马达驱动卷扬机、电机驱动卷扬机以及不带驱动单元的卷扬机，用户根据自己的产品类型见图3、图4，确定合适的安装方法



图3



图4

4.4.1 安装准备

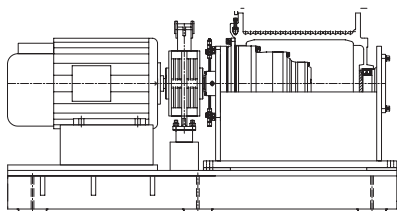
清洁安装配合表面的防腐剂、污物等。

需要安装密封件（O型圈、轴封等）时，请做好保护措施，防止密封件划伤、割伤。

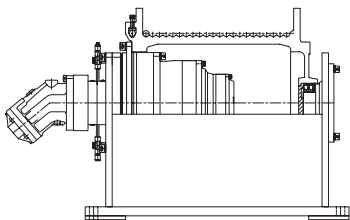
若产品储存时间在一年以上，推荐在安装前更换液压油、润滑剂、润滑油等。

工具/材料的准备：扳手、扭矩扳手、装配夹具、输入和输出紧固装置、润滑剂(防锈油)、密封螺栓的介质(螺纹锁固剂)等。

确认卷扬机的安装尺寸和安装机架连接尺寸一致。

不带驱动单元的卷扬机需确认卷扬机输入接口和驱动单元输出接口尺寸一致。

确认产品及其附件安装顺序。

i 齿轮箱输出法兰与滚筒连接、减速机输出行星架与滚筒支架连接螺栓强度必须为10.9级。

4.4.2 将卷扬机（集成滚筒、驱动单元与附件）安装到设备

若是整套卷扬设备（齿轮箱、驱动单元、滚筒、末端支撑、卷扬支架均包含在内），那么按以下步骤安装卷扬机：

- 1、将卷扬机运送至应用设备处并放置于两根合适的枕木条上。
- 2、将卷扬机用合适的吊装工具可靠地固定在起升设备（行车、吊车）上。
- 3、缓慢起吊卷扬机，并将卷扬机装入机架或车架内。
- 4、请使用强度等级至少为10.9级的螺栓将卷扬机固定，固定螺栓不属于供货范围。
- 5、拆下吊装、起升等辅助工具。

4.4.3 液压马达以及集成阀块安装

若是液压卷扬设备并不包含液压马达，请先按照章节4.4.2所述将卷扬机安装到设备，然后按以下步骤安装液压马达和阀块：

- 1、将液压马达用合适的吊装工具可靠地固定在起升设备（行车、吊车）上。并按图4所示方法运送到卷扬机输入端。



图5：马达起吊示意图

- 2、按照图5所示将O型圈放入输入法兰O型圈槽中。
- 3、双手扶住马达尾部，确保马达安装法兰面与减速机输入法兰面相平行，缓慢推入液压马达，至液压马达完全装入为止。
- 4、请使用强度等级至少为8.8级的螺栓将马达固定，固定螺栓不属于供货范围。
- 5、按照图6所示将O型圈放入阀块油口法兰O型圈槽中。
- 6、请使用强度等级至少为10.9级的螺钉将阀块固定，固定螺钉不属于供货范围。



图6：法兰O型圈安装示意图

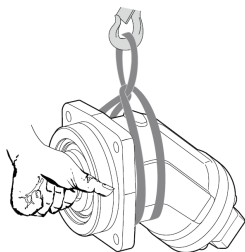

图7：油口O型圈安装示意图

i 安装过程中必须保证O型圈完好，如果O型圈划伤或者挤压变形，必须更换。

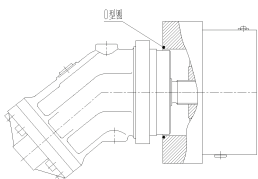
4.4.4 将液压马达驱动卷扬机连接到液压系统

将阀块（马达）A/B油口连接到主液压系统工作油路。

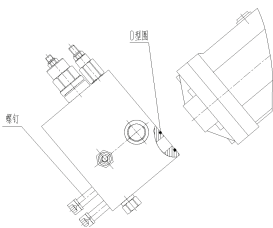
将阀块、马达泄油口连接到主液压系统液压油箱。

将阀块补油口连接到主液压系统补油回路。

将阀块制动油口连接到制动器下侧制动释放油口。

i 为保证卷扬正常工作，马达与马达集成阀块泄油口应直接接回油箱，如果无法接回油箱，必须确保马达泄油口与马达集成阀块泄油口背压均不超过1.5Bar。

为防止驱动马达产生吸空现象，马达集成阀块补油口需提供5-8bar的补油压力。

4.4.5 电机安装

新安装或闲置三个月以上电机使用前必须进行安全性能检查。

安装块式制动器制动轮联轴器时，务必调整好同轴度，同轴度误差大会增大机械振动，导致轴承过早破坏影响齿轮接触。如下图8所示，输入轴与驱动轴通过联轴器安装后，必须用表找正，有关检测参数推荐满足下表《同轴精度表》要求后，设备方可生产运行。

安装接线盒时确保做到清洁，不可进入液体、杂物。

i 电机存储环境湿度较大时，安装前对电机进行干燥处理



图8

同轴精度表

外径D	n<500r/min		500~1500r/min		>1500r/min	
	a1-a2	ΔY	a1-a2	ΔY	a1-a2	ΔY
$D \leq 100$	0.05	0.05	0.04	0.04	0.03	0.03
$100 < D \leq 200$	0.06	0.06	0.05	0.05	0.04	0.04
$200 < D \leq 400$	0.12	0.10	0.10	0.08	0.08	0.06
$400 < D \leq 800$	0.20	0.16	0.16	0.12	0.12	0.10

! 说明：
当联轴器外径的圆周速度在30m/s及以下时，一定要进行静平衡。当外径圆周速度超过30m/s时就要进行动平衡。

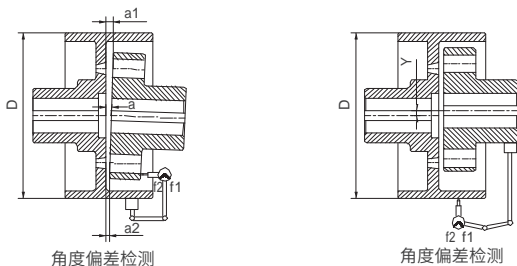
4.4.6 将电机驱动卷扬机连接在电气系统上

将电动机连接到供电系统

将电磁块式制动器连接到供电系统

i 确保制动器瓦块与制动轮表面无润滑油、润滑脂等介质。
电动机在接线前，先检查控制线路、保护电路是否正常，熔断器选用是否合适。

⚡ 电动机机座应有专门的接地保护。
制动器应可靠接地。

4.4.7 将钢丝绳固定到滚筒上

必须使用卡绳装置固定,见图9, 严禁将钢丝绳系在滚筒上。

卡绳孔和卡绳装置不得有锐利的边缘, 钢丝绳的弯曲不得形成锐角。

滚筒上应留3圈过放安全绳, 以提高钢丝绳在滚筒上的摩擦力, 防止钢丝绳从滚筒上抽出。

 钢丝绳的可靠固定至关重要, 必须严格遵守相关要求





图9

4.4.8 附件安装

标准卷扬不包含回程闭锁、钢丝绳过放保护、排绳器等附件。

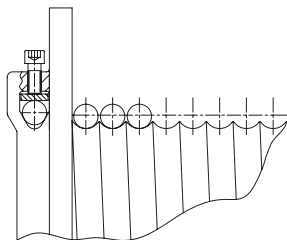
 附件根据不同的使用条件和使用要求需要进行针对性的调试, 具体安装说明请咨询 BONENG 公司技术部门

4.4.9 安装完成

拆下所有安装辅助工具, 如吊环、皮带、吊钩或工装。

请再次检查所有连接元件是否正确固定及其连接强度。

4.4.10 螺栓拧紧力矩

螺栓在摩擦系数为0.125时的拧紧力矩表

螺栓规格	螺栓强度等级8.8	螺栓强度等级10.9
M6	9.5 N.m	13 N.m
M8	23 N.m	32 N.m
M10	46 N.m	64 N.m
M12	80 N.m	110 N.m
M14	125 N.m	180 N.m
M16	195 N.m	275 N.m
M18	270 N.m	390 N.m
M20	385 N.m	540 N.m
M22	510 N.m	720 N.m
M24	660 N.m	930 N.m
M27	980 N.m	1400 N.m
M30	1350 N.m	1850 N.m
M36	2350 N.m	3300 N.m

5 调试

i 请务必按照相关技术数据进行调试，以免损坏设备。
调试前请确保所有电接口和液压接口已连接或封闭。
只有在产品安装完整的情况下方可进行。

5.1 减速机加注润滑油

减速机一般都未带润滑油出厂，在设备运行前，请先加入合适的润滑油。
润滑油液位应达到润滑硬管油镜中部。

表1：润滑油使用温度说明

环境温度	-20℃~+40℃
粘度牌号	VG320

i 环境温度低于-10℃时必须使用合成油。
为确保产品的使用寿命，实际使用中推荐使用合成油。
使用环境温度超过上述范围时，请咨询BONENG公司技术部门。

油量表(L)															
级数 \ 机型	PW20	PW22	PW24	PW25	PW26	PW27	PW29	PW31	PW32	PW33	PW34	PW36	PW38	PW40	
2	3	3	5	6	9	10	16	19	—	—	—	—	—	—	
3	—	—	6	7	10	11	20	22	33	—	—	—	—	—	
4	—	—	—	—	11	12	21	23	35	60	62	75	185	205	

减速机加注润滑油步骤如下：

- 1、确保减速机输入侧润滑硬管下侧螺塞安装可靠。
- 2、拆掉减速机输入侧润滑硬管上侧通气帽，从硬管上侧油口注入润滑油。
- 3、待润滑油液面到达油镜中部并稳定后停止加油。
- 4、拧紧通气帽。



图10：减速机润滑硬管示意图

5.2 液压马达驱动卷扬机调试

在调试卷扬机之前必须备好以下文档：

卷扬机的液压原理图

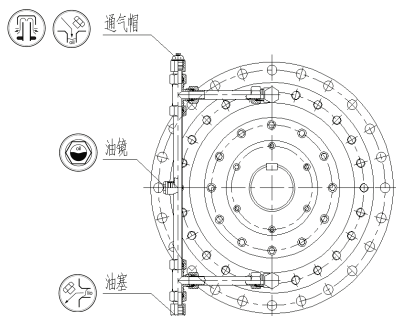
卷扬机所在主机设备液压原理图

液压系统调试大纲

 准备好压力表、测压线等测压附件，以便于记录卷扬机运行状况。

5.2.1 液压系统注油

为了防止卷扬机液压元件损坏并保持功能正常，调试之前必须对马达壳体进行加液和排气。

通过过滤小车等加液设备加液（过滤器精度 $10\mu\text{m}$ ）。卷扬机在加液过程中不得运行。

通过马达壳体上侧泄油口（如图7所示T1口）进行注油，注满为止。





图11：马达油口示意图

 请务必使用矿物油基液压油。如果采用特殊液压油，需要进行技术确认。为确保液压元件寿命，液压油的清洁度等级至少为ISO 4406规定的20/18/15级。当油温很高时（ 85°C 至 110°C ），液压油清洁度等级至少为ISO 4406的19/17/14级。

根据不同的环境选择合适的液压油以保证设备的正常使用。冬天推荐使用液压油粘度等级VG32，对于温度很低的北方环境可使用液压油粘度等级VG22或者低温专用液压油。夏天推荐使用液压油粘度等级VG46，若室外环境温度很高则使用液压油粘度等级VG68。

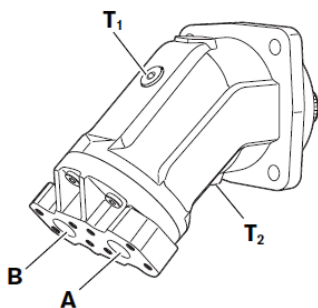
图12所示为不同粘度等级液压油粘温特性，图中阴影部分为液压油最佳使用温度范围，用户可根据设备所处环境温度以及系统热平衡温度选择合适的液压油。



图12：液压油粘温特性

5.2.2 多片式制动器加注润滑油

制动器优先推荐水平安装。

除非特殊说明制动器发运前内腔无油，用户应在使用前加油。

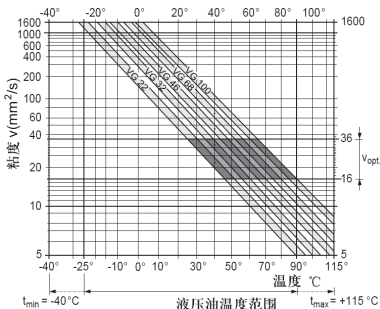
制动器的扭矩是在没有使用抗磨改良油液得到的，含有抗磨改良剂或耐磨添加剂的油液（如EP添加剂、石墨等）将会影响制动扭矩。

制动器加注润滑油步骤如下：

- 1、打开通过制动器上侧加油口,见图13。
- 2、加入润滑油（不同的制动器加油量不同，具体加油量请咨询 BONENG 技术）。
- 3、拧紧加油口螺塞。



图13



制动器只能用作驻车制动，不可用于动态制动。

5.2.3 试运行

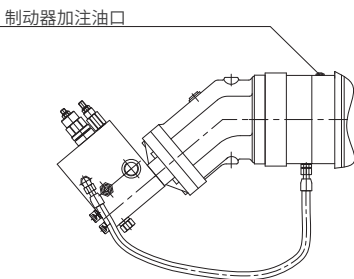
试运行之前再次确认卷扬机安装完成，测压附件均已连接。

若环境温度低于-10°C时，不建议直接冷启动卷扬，推荐用户先对液压油和减速机润滑油进行加热，进行系统预热。

请先在空载的状态下运行卷扬机一段时间，确保管路中排气完成。并检测液压系统运行状况。

卷扬机满足以下条件视为正常运行：



液压系统热平衡参考温度：冬天不超过60°C，夏天不超过80°C。

卷扬机运行时液压元件、制动器、减速机及卷扬机附件均无异响。

减速机参考温升不超过40°C，且最高温度不超过90°C

卷扬机液压系统没有逻辑控制错误。

卷扬机完成空载磨合之后可进行带载测试，请严格按照卷扬机的功率极限和相关技术参数进行测试。

5.3 电机驱动卷扬机调试

电机的启动电流通常是运行电流的5~7倍，连续启动次数不可以超过三次。

调试电机转向为所需转向。

调整电磁块式制动器两侧的瓦块退距，确保等距

调整电磁块式制动器的制动扭矩到所需扭矩



在调试卷扬机之前准备好电气控制原理图

电机运行时正常外壳温度不超过80°C

确保电机风扇通风口空气流畅

电机运行时各相电流与平均值误差不超过10%

电机带载运行转速很低或者不转应立即断电。

6 维护与维修

按照本说明书所述定期进行规定的检修和维护作业。

通过定期护理、维护和检修可以延长产品的使用寿命。

产品的维修在质保期间只能由BONENG售后服务部门完成。如果在质保期内打/改装/修改产品，将导致质保权利的丧失。



请将机器、设备停车，并在卷扬机完全卸载的情况下进行检修/维护和维修作业。

6.1 清洁与护理

在对产品进行任何作业时请注意保持最高的洁净性。

请用合适的护罩和防护装置封闭所有开口，以防清洁剂进入系统。

请使用无纤维织物的干燥布清洁油口。

如有杂物进入液压系统或者齿轮箱，请联系 BONENG 售后服务部门进行专业的拆检清洗，以免加剧液压元件和齿轮箱的磨损。



请勿使用高压清洗机清洁产品。

请勿使用侵蚀性的清洁剂或溶剂，以免腐蚀密封件。

6.2 检查

目检和声检是最直观有效的检查手段。

目检可以检查以下状况：

- 减速机是否漏油。
- 液压系统是否密封完好。
- 减速机油位是否正常。
- 卷扬机各部分是否有过度磨损。

声检可以判断设备设备的运行状况：

- 如减速机出现尖锐的鸣叫声，则表示减速机出现损坏。
- 如液压马达出现较大的响声，则液压系统有可能出现吸空、油液中含有空气。
- 如液压阀块出现尖锐的鸣叫声，则有可能是平衡阀工作不正常。
- 如电机运行时有较大的嗡嗡声，说明电流过大或者缺相运行

6.3 维护计划

表2中所述的“卷扬机/减速机的维护计划”仅适于行星齿轮减速机。因此，请根据设备的维护规范制定行星齿轮减速机的维护计划。

表3中所述的“卷扬机/液压系统及元件的维护计划”仅适于液压系统及元件。因此，请根据设备的维护规范制定液压系统及元件的维护计划。

表4中所述的“卷扬机/电气系统及元件的维护计划”仅适于电气系统及元件。因此，请根据设备的维护规范制定电气系统及元件的维护计划。

表5中所述的“卷扬机/卷扬机附件的维护计划”仅适于卷扬机附件。因此，请根据设备的维护规范制定卷扬机附件的维护计划。

表2：卷扬机/减速机的维护计划

条目	周期
检查油温	每日
检查油面高度	每日
检查减速机的漏油	每月
检查油中的水分	200工作小时后至少每年一次
在启动之后的首次换油	200工作小时后
其后的换油	每年或1000工作小时后
清理通气帽	每三个月
检查紧固螺栓的紧固程度	第一次换油后，每隔一次换油
对于减速机的全面检查	大约每2年和各换油同时进行

表3：卷扬机/液压系统及元件的维护计划

条目	周期
检查液压胶管、液压件油口接头是否存在渗漏油	每日
检查液压元件在工作中是否存在噪音	每周
检查多片式制动器工作时是否存在噪音	每周
多片式制动器润滑油更换	每2000小时
检查液压元件紧固螺栓的紧固程度	每三个月
更换滤芯	根据过滤器厂家周期或当过滤器阻塞报警时
进行液压油分析：粘度、老化程度和污浊度	每年，最迟在2000个运行小时后

表4：卷扬机/电气系统及元件的维护计划

条目	周期
电机更换润滑脂	每六个月
检查电气元件紧固螺栓的紧固程度	每三个月
检查制动器制动瓦退距是否相等	每三个月
更换制动器摩擦片	摩擦片厚度尺寸小于使用要求或烧坏
检查制动器主弹簧松紧力以防溜钩	每三个月

表5：卷扬机/卷扬机附件的维护计划

条目	周期
末端支撑注入润滑脂	每周
检查附件紧固螺栓的紧固程度	每半年
压绳器（排绳器）润滑	每周

6.4 维护说明

卷扬机的使用寿命很大程度上取决于润滑油、液压油的质量。我们因此建议严格控制油液的精度和质量。

6.4.1 液压油更换

卷扬机液压油的更换周期跟随主液压系统而定。
当液压油被污染时必须立刻更换液压油。

6.4.2 减速机润滑油更换

请根据维护计划更换润滑油，只有在卷扬机停机且油温冷却后才能更换润滑油，操作步骤如下：

- 1、请将一个足够大的集液容器置于减速机输入端润滑硬管下方。
- 2、打开减速机输入端润滑硬管上侧通气帽。
- 3、打开减速机输入端润滑硬管下侧螺塞。
- 4、目检所排掉的润滑油是否有水、金属颗粒或杂物存在。如果有严重污染的现象，请在重新加注前找出原因。
- 6、按照章节5.1所述方法加注润滑油

 如果润滑油污浊，请在重新注油前彻底冲洗润滑油系统。

6.4.3 多片式制动器润滑油更换

请根据维护计划更换润滑油，操作步骤如下：

- 1、请将一个足够大的集液容器置于制动器下方。
- 2、打开制动器上侧通气帽。
- 3、打开制动器下侧放油螺塞。
- 4、按照章节5.2.2所述方法加注润滑油

 只有在卷扬机停机、制动器复位且油温冷却后才能更换润滑油

6.5 维修

BONENG为您提供卷扬产品全面的维修服务。

在质保期内，产品必须由 BONENG 售后服务部门进行维修。如果在质保期内私自打开/改装/修改产品，将导致质保权利的丧失。

请务必使用 BONENG 原装的备件对产品进行维修，否则将无法确产品的功能安全性，您将丧失质保权利。

7 拆卸与拆换

您可以使用标准工具拆卸驱动单元。无需专用工具。

拆卸驱动单元时的不正确操作可能使驱动单元受损。

拆卸时请勿敲打产品。不可对驱动单元、减速机外壳等核心部件施加轴向力或这高压力。

请确保产品在拆卸过程中做到轻拿轻放。



确保拆卸现场清洁，防止污物或异物进入液压系统和减速机。
液压卷扬机在拆卸完成后必须将液压元件油口、管路接口封住，做保护处理。



回收拆卸现场的油液、润滑剂等油类介质。



必须在卷扬机停车、卸载并冷却后进行拆卸。

8 故障查询与故障排除

以下故障表可以帮助您查找到故障。我们不担保表中内容的完整性，实际应用中可能出现这里未涉及的问题。

表6为行星减速机故障表

表7为液压系统及元件故障表

表8为电气系统及元件故障表

表9为卷扬机附件故障表



必要时仔细记录发生故障时设备的运行情况，并将信息及时反映给 BONENG 售后服务部门。

如果所发生的故障不包含在上述表中，或者无法排除故障，请及时联系 BONENG 售后服务部门。

表6：行星减速机故障表

故障	可能的原因	排除方法
齿轮机构声音有变化	齿轮受损	1. 检查所有齿轮零部件是否有损坏。 2. 让BONENG售后服务部门更换受损的零部件。
	轴承出现间隙	通知售后
	轴承损坏	
噪音	紧固件松动	将螺栓拧紧到规定扭矩
减速机温度明显高于正常温度	油位过高或过低	1. 让行星齿轮机构冷却。 2. 请检查油位。 3. 补充润滑油或在油位过高时排放一些。
	润滑油过于老化或严重污染	检查设备、机器或车辆的使用手册，查看何时换油，必要时进行换油。请按照章节6.4.2所述步骤作。
漏油	输出端密封件受损	检查密封件，如有可能在必要时进行更换。如果无法排除漏油，必须通知客服。
	输入端轴封损坏	
润滑油起泡	所加注的润滑油与行星齿轮机构中剩余的油或防腐润滑油不匹配	更换润滑油并用合适的冲刷油进行彻底地冲刷。

表7：液压系统及元件故障表

故障	可能的原因	排除方法
马达与制动器安装面漏油	O型密封圈损坏	更换
软管接头处渗油	密封件损坏	更换
卷扬带载下行抖动、不平稳	平衡阀设定压力过低	重新设定平衡阀压力
	平衡阀损坏	维修/更换
卷扬带载时溜钩	马达集成阀块泄油口压力过高	测量马达集成块泄油口压力
	制动器损坏	维修/更换
卷扬运行时制动器异响	制动器开启减压阀设定压力过低	测量马达集成块制动口压力
	制动器损坏	维修/更换
马达运行时出现异响	马达吸空	测量马达集成块补油口压力
	马达损坏	维修/更换
卷扬提升力不足	系统压力不足	测量马达进油口压力
	缓冲阀设定压力过低	重新设定缓冲阀压力
	马达损坏	维修/更换
马达与马达集成阀块安装面漏油	O型密封圈损坏	更换
	马达集成阀块安装面损坏	维修/更换

表8：电气系统及元件故障表

故障	可能的原因	排除方法
电机无法启动	保险丝熔断	更换保险丝
	定子线圈接触不良	打开终端盒，用测试灯确定连接不良的部位。
	电机可能处于过载状态	降低启动负载
	主电源线路故障	检查电源线路
电机转速慢	线路电压降低而导致电机接线端子电压过低	1、使用电压更高的电源或变压器终端。 2、检查接线情况。
	主电路断路、缺相	检查电路是否正常并连接完好
电机振动	支座不稳	加固底座
	联轴器错位	重新平衡联轴器
电机异常响声	轴承损坏	更换
电磁块式制动器制动时声音尖锐	制动衬套磨损严重	更换
制动器无法可靠制动	制动弹簧松动或损坏	维修/更换
制动器打不开	制动弹簧过紧	调整弹簧松紧度

表9：卷扬机附件故障表

故障	可能的原因	排除方法
末端支撑轴承发热	润滑不良	添加适量润滑脂
末端支撑有异常噪音	末端支撑轴承损坏	更换
钢丝绳乱绳	排绳器失效	维修/更换
钢丝绳过放保护失效	过放保护器故障	重新调整三圈保护器

Important notes

When assembling, please note these safety alarms.



Dangerous
Possible result: If disobeyed, may cause death or heavy accident.



Alarm:
Possible result: If disobeyed, may cause heavy hurt or death.



Be careful:
Possible result: If disobeyed, may cause light hurt or damage the gear units.



Suggestion and correct information.



Observing the provisions of this manual can make the device run without failure, and also meet the requirements of quality defect claims. Therefore, please read this manual before using the transmission device for work.

This manual contains important installation and maintenance tips. Please keep the manual close to the equipment for easy installation and maintenance.

1 About products

The products are PW Winches with incorporated built in planetary gear units, we call winch gear units.

1.1 The name plate

BONENG		CE	
Type			
n ₂		RPM	
P ₁	kW	T ₂	N · m
n ₁	RPM	i	
Oil	L		kg
NO.		Date	

Product type
Output RPM
Rated input power KW
Rated output torque N.m
Rated input RPM
Rated ratio
Oil quantity L
Weight
Products number
Exwork date



All the information on the name plate is very important. Please read careful and keep it clean. When service required, please offer the products number on the name plate and the operation time and the fault situation.

1.2 Gear unit type description

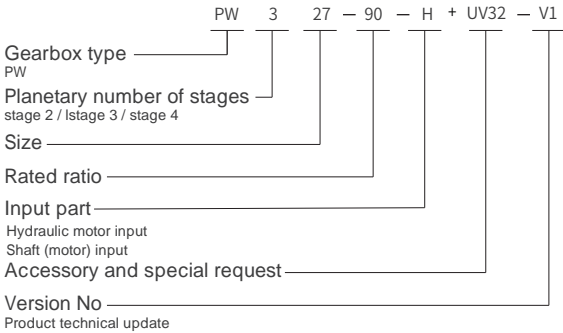

1.3 Feature description

The rated output torque for PW is 11.2KN.m - 1500KN.m, the rated single rope hoist pull force for the steel cable is 67KN - 1950KN. For the specific product feature date, please refer the catalogue or BONENG relative technical material.

1.4 Products description

PW winch gear units are incorporated with built in planetary gear units, drive units, drum, end support and other relative accessories. It is used on crane, pile driving machinery and shipping etc. Because it is seat in the drum, the structure is tight and save the space.

1.4.1 Gear units

PW gear units with big output torque, large range of ratio and stability

The sun gear and planetary gear material are excellent alloy steel which is carburized and quenched, internal gear material is excellent alloy steel which surface is hardened, all the gears are grinded.

Planetary rack and the middle connect flange material are nodular cast iron which has high loading force.

1.4.2 Drive unit

The PW drive unit is hydraulic motor or motor (see figure 1 and 2) .

 When hydraulic motor drive system is open system, it should be equipped with integrate valve block (lighten the pressure, balance the load and switch on the brake etc.) to make sure the hoisting winch working well.

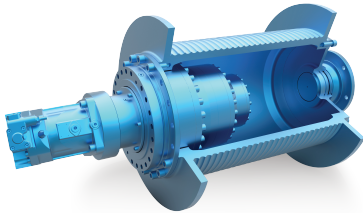

Figure1

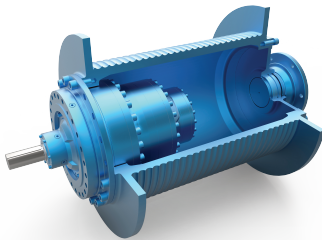

Figure2

1.4.3 Brake

The winch gear unit is equipped with brake to make sure it can be locked when the hoisting winch stop working and make sure the safety.

When the drive is hydraulic motor, the equipped brake is hydraulic loose—spring multi disc brake. Multi disc brake load more on spring, release the hydraulic pressure and act as the stopping brake.

When the drive is motor, the equipped brake is electromagnetic block brake. The block brake is open or close for the electromagnetic block.

1.4.4 Drum

The drum is cast complete structure. The surface of the drum is smooth face, normal grooves or special grooves.

Smooth face drum is used for single rope strand and seldom used.

Normal grooving drum is used for less than three rope strands.

Special grooving drum is used for more than three rope strands. It can avoid to messing the ropes up and extending the steel rope ' s life.

1.4.5 Accessories

As the customer ' s request, hoisting winch accessories include drum, drum support, end support and base etc.

1.5 Notes



Any change on the winch gear unit is prohibited.

Any welding on the winch gear unit is forbidden. And can ' t make the winch gear unit as the welding site, it will damage the precision gear and bearings etc.

Any abnormality happened (For example, Higher temperature or abnormal noise), stop the gear unit immediately and check the fault and solve it.

Make sure use all the original spare parts from Boneng, which can avoid accident by inappropriate spare parts.



If need get the oil sample or drain out the oil lubrication, please open the oil outlet carefully to avoid the oil spray or spill out.



When winch gear unit is operating, not near by it.

Only the winch gear unit is stopped, dismantle work can be done.

2 Safety notes

Winch gear unit is produced as normal technical safe rules. Even if, if disobey the operating instructions, the body or something may be hurt or damaged.

2.1 Proper use

The winch gear unit is an integral machinery including many spare parts. Customer mustn't dismantle or change it by himself.

The winch gear unit can be applied in hoist, luffing and hauling etc.

Must comply with the instructions or the technical documents, do as the operation condition, operation data and the power limited.

Only use under the perfect condition and all data is correct.

2.2 Improper use

Following operation is regarded as incorrect or prohibited. Any incorrect use will not be protected by BONENG.



Break 2.1 proper use items.



Winch gear units are dismantled and the spare parts are used in other ways.

Winch gear units are exposed to use in corrosive environment.



Winch gear units are exposed to use in explosive environment.

Winch gear units are used as loading people etc.

2.3 Qualified staff

The person need have the mechanical, electronic and hydraulic knowledge. The winch gear unit use should be supported by hoisting winch technical knowledge.

To make sure use safely, all work should be done by the qualified or special trained person or done under the qualified person instruction.

2.4 Safety notes



Comply with the accident prevention and environmental protection.

Comply with the local safety and law rules.



During operating, the local temperature (gear unit surface, hydraulic motor housing or motor housing) may heat up 90 °C, do not touch the gear unit surface.



The inflammable articles may cause the hurt or damage. For example, Oil lubrication, hydraulic oil etc. do with them as the supplier's products list and safe data list stipulations.

The dangerous or poisonous articles may harm your health. For example, Oil lubrication, hydraulic oil etc. do with them as the supplier's products list and safe data list stipulations.

3 Transportation and storage

Before transport, please read the instruction carefully and comply with them to stock the gear units.

3.1 Transportation



Comply with the local Country transport law and rules

When lifting by hoist or forklift, must be done by the qualified person.

According to the weight and measurement, choose the correct lifting tool (hoist or forklift) and lifting tools (chain and hook or belt and rope)

During transport, make sure it is fixed well

When transporting, make sure lift and put down lightly to avoid damage.

3.2 Storage



Gear units should be stocked in anti - corrosive condition.

Gear units should be stocked in good ventilation and anti - rust environment. It will be kept well for 12 months.

If stocked in air condition, the anti - rust can be kept for 18 months. Keep away from the humid place.

4 Assembly

Before assembly, prepare following material,

Products overall dimension drawing

Products technical data

Products operation instructions

4.1 Remove the packaging

The standard packing is wooden case. To avoid the damp, the internal pack is with anti - rust film and the dryer.

Follow the steps to remove the packaging:

- 1.Put the packaging on a certain loading and explanate place
- 2.Open the package from up side
- 3.Check the package surface
- 4.Check the gear unit type
- 5.Use the suitable lifting tool to fetch the gear unit out
- 6.Put the gear unit to available place and avoid leaning



DO the packaging disposal as the local law.

4.2 Assembly condition

Confirm the products in good condition (No damage during transporting or stock)

Confirm the coordinate of site condition with the name plate

Make sure the mounting plate or support base can absorb certain torsion. The support base must be designed according to the mass and torque taking into account the forces acting on the gear unit.

Make sure the oil inlet and outlet is sealed well to avoid pollution

When installing outdoors, direct sunshine should be avoided. Otherwise the heat concentration will affect the gear units performance.

Keep certain place for the maintenance and repair.

Any damage caused by incorrect assembly will not be protected by BONENG.



Standard products: ambient temperature: 0 - +40 , no oil, acid, harmful gas, steam, radiomaterial.

4.3 Mounting position

Suggested position is foot mounted

The mounting face is allowed to a certain leaning, but must keep on the same level for the mounting face and the rotor central of winch gear units to avoid messing the ropes up.

The mounting position will affect the direction of ropes, must make the correct mounting.

4.4 Assembly description

Following assemble instructions include the hydraulic motor drive winch gear units, motor drive winch gear units and no any drive gear units. Customer assembles your gear units as following figure 3 and figure 4.

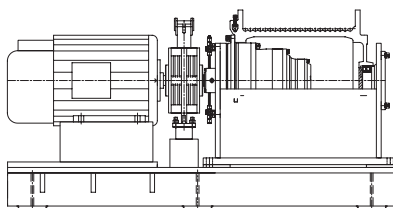

Figure 3

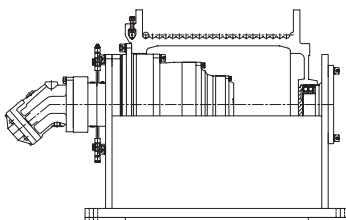

Figure 4

4.4.1 Assembly prepare

Clean the mounting surface.

When mounting the sealing (O type sealing or oil sealing), take measure to avoid scratch it.

When the gear units are stocked over 1 year, change the oil, lubrication and oil lubrication etc before mounting.

Tools: wrench, wrench torque, work piece, input and output fasten device, lubrication (anti - rust oil), screw sealing (screw glue)

Make sure the winch gear unit mounting size is the same as the mount support connection.

If there is no input drive for winch gear unit, confirm the input size of the gear unit is the same as the output size of the drive units.

Confirm the mounting sequence of the spare parts.



When the output flange of gear units connect with the drum and the output planetary support of gear unit connect the drum support, the screw level must be 10.9.

4.4.2 Connect the winch gear unit (complete drum, drive unit and accessories) to the driven machine

If it is the complete winch gear unit (gear unit, drive unit, tube, end support and winch support), do as followings:

- 1.Transport the winch gear unit to the driven machine side and put it on two wood beams.
- 2.Lift the gear unit and fix it on the hoisting tools (hoist or crane).
- 3.Lift the gear unit slowly and put it to rack housing or frame.
- 4.Use 10.9 tighten level screw to fix the hoist gear unit. The screw supplied by customer.
- 5.Remove the hoist or lift tools.

4.4.3 Hydraulic motor and the integrate valve block mounting

If it is the hydraulic winch gear unit exclusive the hydraulic motor, do as 4.4.2 till the winch gear unit are mounted on the driven machine, then assemble the hydraulic motor and valve block as followings :

- 1.Lift the hydraulic motor and fix it on the hoisting tools (hoist or crane). Transfer it to the input part of winch gear unit according figure 4

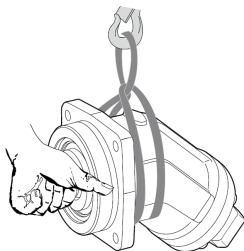

Figure 5 : Motor lifting

2. Put O ring into the O ring groove of input flange as figure 5
3. Hold the end of motor by hands to make sure the flange face is on the same level with the input flange face of gear unit and then push the hydraulic motor into the input flange of gear unit.
4. Use 8.8 tighten level screw to fix the motor. The screw supplied by customer.
5. Put O ring into the O ring groove of valve block oil port as figure 6
6. Use 10.9 tighten level screw to fix the valve block. The screw supplied by customer.

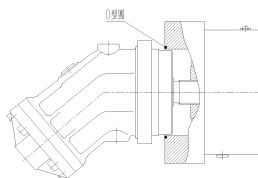

Figure 6 : Flange O ring mounting

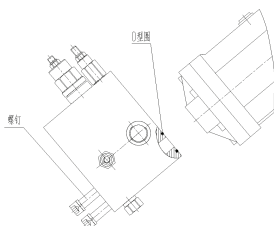

Figure 7 : Oil port O ring mounting

i Must keep the O ring perfect during assembly, if there is scratch or crush, replace the new one.

4.4.4 Connect the hydraulic motor winch gear unit with the hydraulic system

Connect the A/B oil port of the valve block (motor) with the oil system of the main hydraulic device.

Connect the oil outlet of valve block and motor with the oil tank of hydraulic system.

Connect the oil inlet of valve block with the oil inlet of hydraulic system.

Connect the brake oil port of valve block with the brake release oil port of the brake.

i To make sure the winch gear unit run well, the oil outlet of motor and motor integrate valve block should connect with the oil tank directly, if not, must make sure the pressure of the motor and motor integrate valve block is not more than 1.5 Bar. To avoid the oil empty suck of the motor drive, must keep 5-8 bar oil pressure on the motor integrate valve oil inlet.

4.4.5 Motor mounting

For the new assembled or stocked over 3 months motor, must check the safety before using. When assemble the coupling with brake block, must align the coaxiality. Big coaxial tolerance will cause the vibrations which will damage the bearings and the mesh of gears. When the motor shaft connect with the input shaft of gear unit by coupling (figure 8), must align the level by meter and meet the following data showed in " the coaxial precision table " . When connect the box terminal, must keep it clean, no liquid or waste.

i If the stock environment for motor is very moist, dry the motor before mounting.

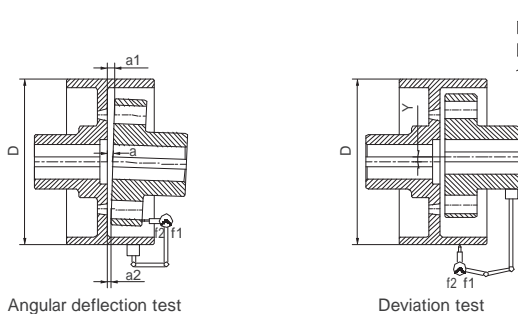

Figure 8

The coaxial precision table

External diameter D	n<500r/min		500~1500r/min		>1500r/min	
	a1-a2	ΔY	a1-a2	ΔY	a1-a2	ΔY
$D \leq 100$	0.05	0.05	0.04	0.04	0.03	0.03
$100 < D \leq 200$	0.06	0.06	0.05	0.05	0.04	0.04
$200 < D \leq 400$	0.12	0.10	0.10	0.08	0.08	0.06
$400 < D \leq 800$	0.20	0.16	0.16	0.12	0.12	0.10



Notes

When the outside diameter peripheral velocity of the coupling is less 30m/s, must do the static balancing. When the outside diameter peripheral velocity is over 30m/s, must do the dynamic balancing.

4.4.6 Connect the motor drive winch gear unit with the electric system

Connect the motor with the electric system

Connect the electromagnetic brake with the electric system



Confirm no oil or lubrication grease on the brake block and the brake wheel
Check the wire, protective circuit and fuse plug before connecting the motor.



Special earth protector should be done for motor base.

Brake should do safe earth connection.

4.4.7 Fix the rope on the drum

Must use the rope clamps to fasten the rope, see figure 9. Fixing the rope to the drum directly is not allowed.

Keep smooth for the hole and the rope clamps, sharp angle are not formed if the rope bends. Keep 3 rope strands for the over - discharging safe ropes to add the friction force and prevent the steel rope pull out from the drum.

 It ' s very important to fix the steel ropes, must comply with relative rules.

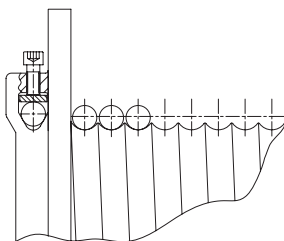



Figure 9

4.4.8 Accessories

Standard winch gear units don ' t include the backhaul lock, steel rope over - discharging protection, spooling guider.

 As different application and request, adjust the accessories accordingly. For details, consult BONENG Technical department.

4.4.9 Assembly completed

Remove all tools, such as lifting eyes, belt, hooks and work piece.

Recheck all the connection units correct fixed and tightened

4.4.10 Screw tighten torque

When the friction factor is 0.125, the screw tighten torque is showed as following table.

Screw type	Screw strength 8.8	Screw strength 10.9
M6	9.5 N.m	13 N.m
M8	23 N.m	32 N.m
M10	46 N.m	64 N.m
M12	80 N.m	110 N.m
M14	125 N.m	180 N.m
M16	195 N.m	275 N.m
M18	270 N.m	390 N.m
M20	385 N.m	540 N.m
M22	510 N.m	720 N.m
M24	660 N.m	930 N.m
M27	980 N.m	1400 N.m
M30	1350 N.m	1850 N.m
M36	2350 N.m	3300 N.m

5 Debugging



Test according to the relative technical data to avoid the damage. Before debugging, make sure all the connections for electric or hydraulic are done or closed. Do debugging till all assembly work finished.

5.1 Fill the lubrication in gear unit

The gear units are out of lubrication before delivery, please fill the oil lubrication before running.

The oil level should be on the middle of the oil glass.

Table 1: Lubrication

Ambient temperature	-20 ~+40
Adhesiveness of oil brand	VG320



When ambient temperature is lower than -10 , use synthetic oil only.

To length the gear unit life, suggest to use synthetic oil.

When ambient temperature is over the range of the table, please consult BONENG technical department.

Oil Level (L)														
Gear unit type	PW20	PW22	PW24	PW25	PW26	PW27	PW29	PW31	PW32	PW33	PW34	PW36	PW38	PW40
2	3	3	5	6	9	10	16	19	—	—	—	—	—	—
3	—	—	6	7	10	11	20	22	33	—	—	—	—	—
4	—	—	—	—	11	12	21	23	35	60	62	75	185	205

The step of filling oil is as followings,

1. Make sure the screw plug under the lubrication tube on the input part fixed well.
2. Remove the breather on the top of the lubrication tube on the input part, and fill the oil from the top oil port.
3. Stop filling the oil when the lubrication oil level on the middle of the oil glass.
4. Tighten the breather.

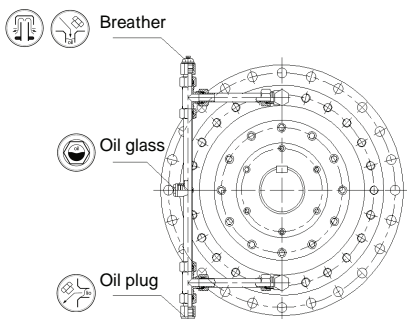

Figure10: The lubrication tube structure

5.2 The debugging for the hydraulic motor winch gear unit

Prepare following documents before debugging:

- The hoist gear unit hydraulic principle diagram.
- The driven machine hydraulic principle diagram.
- The outline for hydraulic system.

i Prepare the pressure meter and pressure test line to record the winch gear unit running.

5.2.1 Filling oil for hydraulic system

To prevent the winch gear unit hydraulic parts, please fill the oil and draw the air out on motor housing before debugging.

Fill the oil by the filter car (filter precession is $10\mu\text{m}$). Running is not allowed when filling oil.

Fill the oil through the upper oil inlet on the motor housing (see figure 7 T1) with full.

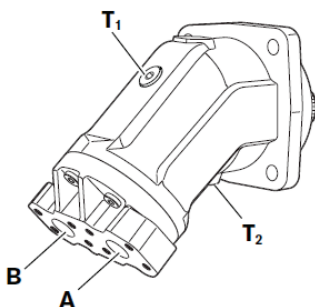

Figure11 : Motor oil inlet

i Must use mineral oil. If need use special oil, must get the approval from BONENG technician.

For the sake of hydraulic unit life, the oil cleanliness level should be kept above 20/18/15 stipulated in ISO 4406. When oil temperature is very high (85 - 110), the cleanliness for the oil should be kept above 19/17/14 as ISO 4406 stipulated.

Choose suitable lubrication oil to make sure the gear unit running well if the temperature is different. Suggest use VG32 in winter, for very low temperature, suggest use VG22 or special oil for the lower temperature. And suggest use VG46 in summer. If the outside temperature is very high, suggest use VG68.

Suggest the oil adhesiveness and brand in figure 12, the part with shadow is the best temperature for the relative oil brand. Customer can choose the suitable oil brand according to the ambient temperature and machine average temperature.

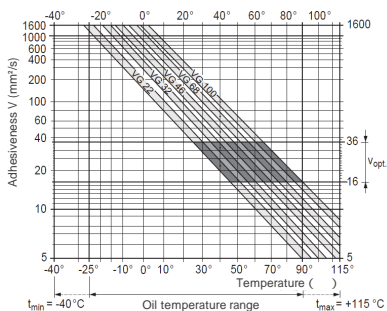

Figure12 : Oil adhesiveness

5.2.2 Filling oil for multi piece brake

Suggest foot mounted.

Brake is out of lubrication before delivery, please fill the oil lubrication before running.

The brake torque is produced without any wearable lubrication oil. The wearable lubrication (For example EP additive or graphite) will effect on the torque of brake.

The steps for filling the oil on brake:

1. Open the oil inlet upper on the brake, see figure 13
2. Filling the oil (Different brake will fill different oil level, for exact oil level, please consult BONENG technical department)
3. Tighten the oil plug

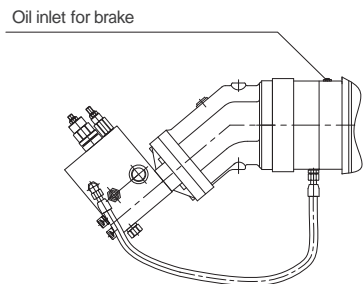

Figure 13



Brake is used for parking brake and not allowed to use for dynamic brake.

5.2.3 Running test

Make sure the winch gear unit assembly completed and all the pressure testing accessories are connected well before running test.

When temperature is lower - 10 , suggest heat the hydraulic oil and lubrication oil of gear units first then start up the winch gear unit.

Running the winch gear unit for some times without loading to make sure all the air in the tube is exhausted. And check the pressure system to operate well.

Winch gear units are regarded as normal when meeting following points :



The hydraulic system heat balance temperature: less than 60 in winter and less than 80 in summer.

When operating, there is no noise on hydraulic unit, brake, gear units and hoist accessories. The reference temperature rise is not over 40 and the gearbox temperature is not over 90 .

There should be no logic mistake on the winch hydraulic system.

When complete the no load test, the winch gear units can be tested with load.

Please do the test as the limited power and relative technical data.

5.3 Motor drive winch gear unit debugging

The motor starting electric current is 5 to 7 times than operating current, the continuous starting times is not more than 3.

Adjust the motor rotation as required.

Adjust the distance on the electromagnetic brake pad and keep the same distance.

Adjust the brake torque of the electromagnetic brake as required.



Prepare the electric control principle diagram before debugging.

During motor operating, the housing surface temperature is not over 80 .
Make sure the motor fan ventilate well.

The tolerance of current and average on phase is not exceeded of 10% during motor operating.

Switch off the motor immediately when the motor rotor speed is very low or not run with loading.

6 Maintenance and repair

Maintenance should be made periodically as this instruction.

Lengthen the gear unit life through the periodical maintenance and repair.

The after sales service person of BONENG will do the repair during the quality warranty.

The quality warranty will be invalid if customer dismantle, change or repair the gear unit during warranty period.



Do the maintenance and repair only when machine and equipments are stopped and the winch gear unit is dismantled completely.

6.1 Clean and maintenance

Keep the winch gear unit clean and make sure the gear unit to work normally.

Using the suitable cover and protect device to seal all the ports to prevent the cleaner to enter into the system.

Clean the oil port using dry cotton fabric.

If the raffle penetrates into the hydraulic system or gear unit, please contact BONENG after sales service and we will do the special washing to avoid damage the hydraulic unit and gear unit.



Jetting machine is forbidden to clean the hoist gear unit.

Corrosive cleaner or solvent is not allowed.

6.2 Checking

Checked by eyes and sound are the best way.

Following situation can be checked by eyes:

- The oil leakage from winch gear unit.
- Well sealing on hydraulic system.
- Normal oil level on gear unit.
- No over abrasion on the part of winch gear units.

Following situation can be checked by sound:

- If there is harsh noise, it shows the gear unit damaged.
- If there is big noise from hydraulic motor, it shows the hydraulic system is sucking air and there is air in the lubrication oil.
- If there is harsh noise from hydraulic valve block, it shows the balance valve is working wrong.
- If there is big hum when motor operating, it shows the electric current is big or operate with default phase.

6.3 Maintenance plan

Table 2 “ Winch gear units/ gear units maintenance plan ” is only suitable for planetary gear unit. Please do the planetary gear unit maintenance plan as the equipment maintenance rules.

Table 3 “ Winch gear units/hydraulic system and accessories maintenance plan ” is only suitable for hydraulic system and accessories. Please do the hydraulic system and accessories maintenance plan as the equipment maintenance rules.

Table 4 “ Winch gear units/electric system and accessories maintenance plan ” is only suitable for electric system and accessories. Please do the electric system and accessories maintenance plan as the equipment maintenance rules.

Table 5 “ Winch gear units/hoist gear units accessories maintenance plan ” is only suitable for winch gear units accessories. Please do the winch gear units accessories maintenance plan as the equipment maintenance rules.

Table 2 winch gear units/ gear units maintenance plan

Measures	Periods
Check oil temperature	Daily
Check oil level	Daily
Check gear unit for leaks	Monthly
Test oil for water content	After approx.200 operating hours once per year at least
First oil change	200 operating hours following start - up
Subsequent oil changes	Every year or 1000 operating hours
Clean the breather	Every 3 months
Check tightness of fastening bolts	After first oil change, thereafter, after every second oil change
Carry out complete inspection of gear unit	Approx. every 2 years simultaneously with due oil change

Table 3 winch gear units/hydraulic system and accessories maintenance plan

Measures	Periods
Check the hydraulic hose, oil port connection for leaks	Daily
Check the noise during the hydraulic accessories working	Weekly
Check the noise during the multiple disc brake working	Weekly
Change the lubrication oil for the multiple disc brake	Every 2000 hours
Check tightness of fastening bolts for the hydraulic accessories	Every 3 months
Change the filter element	According to the filter period or the alarm from filter
Analysis the oil: adhesive, degree of aging and muddiness	After 2000 operating hours once per year at least

Table 4 winch gear units/electric system and accessories maintenance plan

Measures	Periods
Change the grease for motor	Every 6 months
Check tightness of fastening bolts for electric accessories	Every 3 months
Check the same distance on the brake pad	Every 3 months
Change the brake friction plate	The thickness for the brake friction is lower than the stipulated or be burned
Check tightness of main spring for brake	Every 3 months

Table 5 winch gear units/winch gear units accessories maintenance plan

Measures	Periods
Filling grease in the end support	Weekly
Check tightness of fastening bolts for winch gear units accessories	Every 6 months
Lubrication for rope guider	Weekly

6.4 Maintenance notes

The winch gear units life depends on the lubrication oil and hydraulic oil quality. Must control the oil quality.

6.4.1 Hydraulic oil change

The oil change period of winch gear unit is depend on the main hydraulic system.

When Oil badly contaminated, must change the hydraulic oil immediately.

6.4.2 Gear units oil change

Change the lubrication oil as the maintenance plan, and do it only after the winch gear unit lubrication oil should cool down. The procedure is done as followings:

- 1.Put a bigger container under the tube of gear unit input part.
- 2.Open the breather on the top of the lubrication tube on the input part.
- 3.Loose the screw plug under the lubrication tube on the input part.
- 4.Check whether the oil is mixed with water, prill or sundries by eyes. If contaminated badly, please find the causes before filling new oil.
- 5.Filling the oil as the state of 5.1.



If the lubrication oil is contaminated, please clean the lubrication stem thoroughly.

6.4.3 Multiple piece brake lubrication oil change

Change the lubrication oil as the maintenance plan, the procedure is as followings:

- 1.Put a bigger container under the brake.
- 2.Open the breather on the top of brake.
- 3.Loose the oil screw plug under the brake side.
- 4.Filling the oil as the state of 5.2.2



Change the lubrication oil only after the winch gear unit stopping, brake running back and oil cooling down.

6.5 Repair

Boneng will offer the complete service for the winch gear units.

During warranty, repaired working should be done by the after sales service of Boneng.

If dismantle the gear units/ change/ alter the product by self, the quality guarantee will be invalid.

Must use the original spare parts from Boneng for repair.

7 Dismantling and replace

Use the standard tools to dismantle the drive unit, special tools are not needed.

Incorrect operating will hurt the drive units.

Hitting products is forbidden when dismantle. No shaft force or high pressure on the core parts of drive units and the housing of gear units.

Handle the products lightly during dismantle.



Keep the dismantle spot is clean and keep the contaminant away from the hydraulic system and gear units.

After dismantle on the hydraulic winch gear unit, must keep the hydraulic unit oil port and tube connection sealed and protect them.



Recycle the oil and lubrication etc.



Do the dismantle working only after the winch gear units stopping, no loading and cooling down.

8 Faults checking and resolve

Following faults checking table will help you to find the reason. We can ' t make sure it is complete, in fact, there may be the reason excluded in the table.

Table 6 planetary gear units fault.

Table 7 hydraulic system and unit fault.

Table 8 electric system and unit fault.

Table 9 winch gear unit accessories fault.



Record the fault problem and send the information to customer service of Boneng in time. If the faults are not found in above table, and can ' t find the problem, please contact the customer service of Boneng.

Table 6 planetary gear units fault

Malfunctions	Causes	Remedy
Changes in gear unit noise	Damage to gear teeth	1.Check all teeth 2.Replace any damaged parts
	Excessive bearing play	Contact customer service
	Bearing defective	
Loud noises	Fastening is loose	Tighten bolts/nuts to prescribed torque
Operating temperature too high	Oil level in gear unit housing too high or too low	1.Cooling the planetary gear units. 2.Check oil level 3.Filling more oil or drain out some oil if the level is too high
	Oil too old or badly contaminated	Check date of last oil change. And change the oil if necessary. Do it as the state on 6.4.2
Oil leakage	Output sealing defective	Check the sealings, if necessary, replace seals. If can ' t confirm the problem, contact customer service.
	Input sealing defective	
Oil foams	The new filled oil is not matched with the remained oil in the gear units	Clean the oil and change the new oil.

Table 7 hydraulic system and unit fault.

Malfunctions	Causes	Remedy
Oil leakage on the connection of motor and brake	O type sealing rings defective	Change the seals
Oil leakage on the connection of hose	Sealing rings defective	Reset the balance valve pressure
Vibration when winch gear unit operating with load	Balance valve pressure is too low	Reset the balance valve pressure
	Balance valve defective	Repair/ change
Slip when winch gear unit operating with load	Oil port pressure on motor integrate valve is too high	Check the oil port pressure on motor integrate valve
	Brake damaged	Brake damaged
Brake noise when winch gear unit operating	The pressure on the reducing valve is too low	Check the brake pressure on motor integrate block
	Brake damaged	Repair/ change
Noise when motor operating	Motor sucks air	Check the brake pressure on motor integrate block
	Motor defective	Repair/ change
The hoist force is not enough	System pressure is not enough	Check the motor oil inlet pressure
	Cushion valve pressure is too low	Reset the cushion valve pressure
	Motor defective	Repair/ change
Oil leakage from the mounting face of motor and motor integrate block	O type sealing rings defective	Change
	The mounting face of motor integrate block is damaged	Repair/ change

Table 8 electric system and unit fault

Malfunctions	Causes	Remedy
Motor doesn ' t run	Fuse burn out	Change the fuse
	Bad contact on stator coil	Open terminal box and test the bad contact point with testing light
	Motor may be with over loading	Reduce the load
	Main wire defective	Check the electric wire
Motor rote speed is slow	Electric pressure is low	1.Use the more higher pressure power or use the voltage transformer 2.Check the circuit connection
	Main circuit break, default phase	Check the electric wire connection
Motor vibration	Support base is unstable	Fasten the support base
	Coupling position is incorrect	Correct the coupling position
Abnormal noise from motor	Bearing defective	change
Loud noise from the magnetic block brake	Brake bush is badly worn	change
Brake bad	Brake spring is loose or damaged	Repair/change
Brake can ' t work	Brake spring is too tight	Adjust the spring tightness

Table 9 hoist gear unit accessories fault

Malfunctions	Causes	Remedy
End support bearing is hot	Bad lubrication	fill suitable grease
Noise from end support	End support bearing defective	change
Steel rope messed up	Rope guide defective	Repair/change
Overprotection of steel rope is invalid	Overprotection device defective	Adjust the three wind protection device

售后服务

各种传动设备，客户发现有质量问题时，不要先拆卸零件，应说明以下情况然后与本公司售后服务部联系，说明现象后确认问题所在，再采用较理想的方法处理。

登录“www.boneng.com”

点击“服务”

点击“售后服务”



博能传动

退出 | 中文 (Chinese)

BONENG®

首页 / 支持 / 售后服务

售后服务

我的售后 >

姓名

电话

邮箱

客户名称

• 产品序列号

• 问题描述

现场单位名称

• 取场地址

设备制造商名称

问题部位照片/视频

姓名	<input type="text"/>
电话	<input type="text"/>
邮箱	<input type="text"/>
客户名称	<input type="text"/>
• 产品序列号	<input type="text" value="产品序列号"/>
• 问题描述	<input type="text" value="问题描述"/>
现场单位名称	<input type="text" value="现场单位名称"/>
• 取场地址	<input type="text" value="国家"/> <input type="text" value="请输入详细地址"/>
设备制造商名称	<input type="text" value="设备制造商名称"/>
问题部位照片/视频	<input style="border: 1px dashed gray; width: 100px; height: 50px; text-align: center; vertical-align: middle;" type="text" value="+"/>

提交

其他地区

控制器/驱动器 华东区技术支持/调试/售后服务：

电话: 0512-66182005

马达/齿轮马达/齿轮箱 华东区技术支持/售后服务：

电话: 0512-66189918

博能传动（沈阳）有限公司

控制器/驱动器 技术支持/调试/售后服务：
电话: 024-31271571
马达/齿轮马达/齿轮箱 技术支持/售后服务：
电话: 024-31292571

博能传动（天津）有限公司

控制器/驱动器 技术支持/调试/售后服务：
电话: 022-86928559
马达/齿轮马达/齿轮箱 技术支持/售后服务：
电话: 022-26929558

博能传动（开封）有限公司

控制器/驱动器 技术支持/调试/售后服务：
电话: 0371-23335230
马达/齿轮马达/齿轮箱 技术支持/售后服务：
电话: 0371-23277771

博能传动（潍坊）有限公司

控制器/驱动器 技术支持/调试/售后服务：
电话: 0536-4699687
马达/齿轮马达/齿轮箱 技术支持/售后服务：
电话: 0536-4699667

博能传动（长沙）有限公司

控制器/驱动器 技术支持/调试/售后服务：
电话: 0731-88386958
马达/齿轮马达/齿轮箱 技术支持/售后服务：
电话: 0731-88380725

博能传动（苏州）有限公司

控制器/驱动器 苏南区技术支持/调试/售后服务：
电话: 0512-66182005
马达/齿轮马达/齿轮箱 苏南区技术支持/售后服务：
电话: 0512-66189918
控制器/驱动器 浙沪区技术支持/调试/售后服务：
电话: 0512-66182005
马达/齿轮马达/齿轮箱 浙沪区技术支持/售后服务：
电话: 0512-66189918
控制器/驱动器 苏皖区技术支持/调试/售后服务：
电话: 0512-66182005
马达/齿轮马达/齿轮箱 苏皖区技术支持/售后服务：
电话: 025-52171612

博能传动（美国）有限公司

技术支持/调试/售后服务：
1250 E 222nd Euclid, OH 44117, United States
Email: America@boneng.com
Office Tel: 1-216-618-3099 / 1-216-618-0138

新德里办事处

技术支持/调试/售后服务：
No. 402, Deep Shikha Building, 8, Rajendra Place, New Delhi - 110 008, INDIA.
Email: india@boneng.com
Tel: +91-11-4507 6293

孟买办事处

技术支持/调试/售后服务：
No. 603, Bhumiraj Costa Rica commercial building, Plot No. 1&2,
Palm Beach Service Road, Sector 18, Sanpada, Navi Mumbai - 400705, India.
Tel: +91-22-2781 3385

印度工厂

技术支持/调试/售后服务：
Plot No. E-10/3, MIDC sinner (Malegaon) Industrial Area, Nashik, 422123, Maharashtra, India.
Email: india@boneng.com

After-sale service

For the various kinds of transmission devices, if there is any quality problem, don't tear down components, you should illustrate the situation, then contact with after-sales department of the company, confirm about the problems, then apply ideal method to deal with them.

Logging in " www.boneng.com "

Click " Service "

Click " After Service "

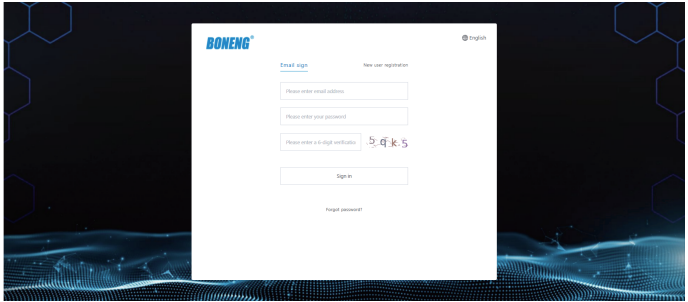

BONENG

Sign Out | English



home / Support / After-sales Service

After-sales Service

My After-sales >

Name	<input type="text"/>
Phone	<input type="text"/>
Email	<input type="text"/>
Company Name	<input type="text"/>
* Product serial number	<input type="text" value="Product serial number"/>
* Problem description	<input type="text" value="Problem description"/>
The name of local company	<input type="text" value="The name of local company"/>
* The site address	<input type="text" value="Countries"/> <input type="text" value="Please enter the detailed address"/>
Name of equipment Manufacturer	<input type="text" value="Name of equipment Manufacturer"/>
Photos/videos of problem parts	<input style="border: 1px dashed gray; width: 100px; height: 50px; text-align: center; vertical-align: middle;" type="text" value="+"/>

Submit

Other District

Controller/Drive East China Technical Support/Debugging/After - Sales Service :
TEL: 0512 - 66182005

Motor/Gear motor/Gearbox East China Technical Support/After - Sales Service :
TEL: 0512 - 66189918

BONENG TRANSMISSION(SHEN YANG)CO.,LTD

Controller/Drive Technical Support/Debugging/After - Sales Service :
TEL: 024 - 31271571
Motor/Gear motor/Gearbox Technical Support/After - Sales Service :
TEL: 024 - 31292571

BONENG TRANSMISSION(TIAN JIN)CO.,LTD

Controller/Drive Technical Support/Debugging/After - Sales Service :
TEL: 022 - 86928559
Motor/Gear motor/Gearbox Technical Support/After - Sales Service :
TEL: 022 - 26929558

BONENG TRANSMISSION(KAIFENG)CO.,LTD

Controller/Drive Technical Support/Debugging/After - Sales Service :
TEL: 0371 - 23335230
Motor/Gear motor/Gearbox Technical Support/After - Sales Service :
TEL: 0371 - 23277771

BONENG TRANSMISSION(WEIFANG)CO.,LTD

Controller/Drive Technical Support/Debugging/After - Sales Service :
TEL: 0536 - 4699687
Motor/Gear motor/Gearbox Technical Support/After - Sales Service :
TEL: 0536 - 4699667

BONENG TRANSMISSION(CHANGSHA)CO.,LTD

Controller/Drive Technical Support/Debugging/After - Sales Service :
TEL: 0731 - 88386958
Motor/Gear motor/Gearbox Technical Support/After - Sales Service :
TEL: 0731 - 88380725

BONENG TRANSMISSION(SUZHOU)CO.,LTD

Controller/Drive Southern Jiangsu Technical Support/Debugging/After - Sales Service :
TEL: 0512 - 66182005
Motor/Gear motor/Gearbox Southern Jiangsu Technical Support/After - Sales Service :
TEL: 0512 - 66189918
Controller/Drive Zhejiang - Shanghai Technical Support/Debugging/After - Sales Service :
TEL: 0512 - 66182005
Motor/Gear motor/Gearbox Zhejiang - Shanghai Technical Support/After - Sales Service :
TEL: 0512 - 66189918
Controller/Drive Jiangsu - Anhui District Technical Support/Debugging/After - Sales Service :
TEL: 0512 - 66182005
Motor/Gear motor/Gearbox Jiangsu - Anhui Technical Support/After - Sales Service :
TEL: 025 - 52171612

BONENG TRANSMISSION(USA/Canada)CO.,LTD

Technical Support/Debugging/After - Sales Service :
1250 E 222nd Euclid, OH 44117, United States
Email: America@boneng.com
Office Tel: 1 - 216 - 618 - 3099 / 1 - 216 - 618 - 0138

Delhi Office

Technical Support/Debugging/After - Sales Service :
No. 402, Deep Shikha Building, 8, Rajendra Place, New Delhi - 110 008, INDIA.
Email: india@boneng.com
Tel: +91 - 11 - 4507 6293

Mumbai Office

Technical Support/Debugging/After - Sales Service :
No. 603, Bhumiraj Costa Rica commercial building, Plot No. 1&2,
Palm Beach Service Road, Sector 18, Sanpada, Navi Mumbai - 400705, India.
Tel: +91 - 22 - 2781 3385

Factory

Technical Support/Debugging/After - Sales Service :
Plot No. E - 10/3, MIDC sinner (Malegaon) Industrial Area, Nashik, 422123, Maharashtra, India.
Email: india@boneng.com

PW Winch Gear Units Use Manual

PW行星内藏式卷扬齿轮箱使用手册

BONENG

BONENG